

Eclipse Air Heat Burner

Series TAH-R

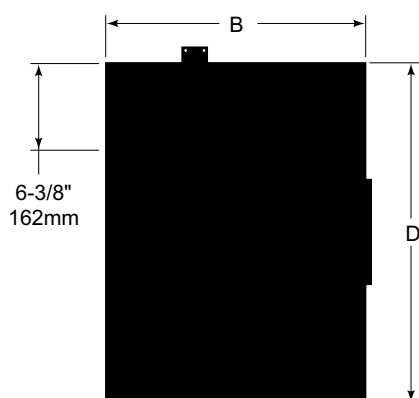

US Reissue Pat. No. 26, 244
Canadian Pat. No. 743, 782

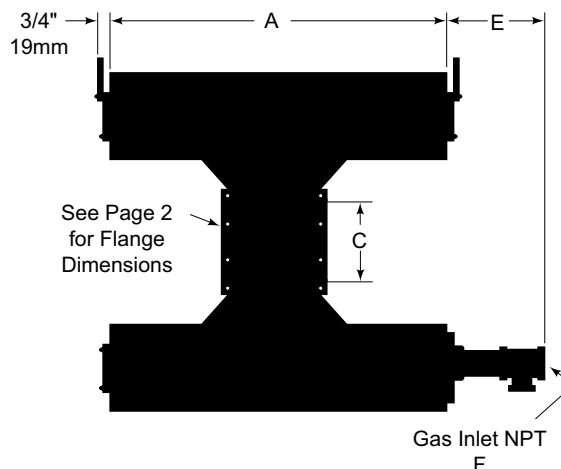

240 TAH-R	109435	2.4 (703)	3.0 (879)	65-84S-1/3	12-1/8 (308)	12-5/16 (313)	6 (152)	18-7/8 (479)	9-1/2 (241)	2	230 (1484)	A	121 (55)
280 TAH-R	109436	2.8 (821)	3.5 (1026)	66-94S-3/4	12-1/8 (308)	12-5/16 (313)	12 (305)	24-7/8 (632)	9-7/8 (251)	2	269 (1736)	C	138 (63)
320 TAH-R	109437	3.2 (938)	4.0 (1172)	66-94S-3/4	12-1/8 (308)	12-5/16 (313)	12 (305)	30-7/8 (784)	9-7/8 (251)	2	307 (1981)	C	159 (72)
360 TAH-R	109438	3.6 (1055)	4.5 (1319)	66-94S-3/4	12-1/8 (308)	18-13/16 (478)	12 (305)	36-7/8 (937)	9-7/8 (251)	2	345 (2226)	C	179 (81)
400 TAH-R	109439	4.0 (1172)	5.0 (1466)	66-94S-3/4	24-1/8 (613)	18-13/16 (478)	12 (305)	18-7/8 (479)	9-7/8 (251)	2	383 (2471)	D	201 (91)
440 TAH-R	109440	4.4 (1290)	5.5 (1612)	66-94S-3/4	24-1/8 (613)	18-13/16 (478)	12 (305)	24-7/8 (632)	10-1/2 (267)	3	422 (2723)	C	219 (99)
480 TAH-R	109441	4.8 (1407)	6.0 (1759)	67-115S-1-1/2	24-1/8 (613)	18-13/16 (478)	12 (305)	30-7/8 (784)	10-1/2 (267)	3	460 (2968)	C	243 (110)
520 TAH-R	109442	5.2 (1524)	6.5 (1905)	67-115S-1-1/2	24-1/8 (613)	18-13/16 (478)	18 (457)	36-7/8 (937)	10-1/2 (267)	3	498 (3213)	C	274 (124)
560 TAH-R	109443	5.6 (1641)	7.0 (2052)	67-115S-2	36-1/8 (918)	18-13/16 (478)	18 (457)	18-7/8 (479)	10-1/2 (267)	3	536 (3458)	D	306 (139)
600 TAH-R	109444	6.0 (1759)	7.5 (2198)	67-115S-2	36-1/8 (918)	18-13/16 (478)	18 (457)	24-7/8 (632)	10-1/2 (267)	3	575 (3710)	C	339 (154)
640 TAH-R	109445	6.4 (1876)	8.0 (2345)	67-115S-2	36-1/8 (918)	18-13/16 (478)	18 (457)	30-7/8 (784)	10-1/2 (267)	3	613 (3955)	C	354 (161)
680 TAH-R	109446	6.8 (1993)	8.5 (2491)	78-126S-3	36-1/8 (918)	18-13/16 (478)	18 (457)	36-7/8 (937)	10-1/2 (267)	3	651 (4200)	C	380 (172)
720 TAH-R	109447	7.2 (2110)	9.0 (2638)	78-126S-3	36-1/8 (918)	18-13/16 (478)	18 (457)	42-7/8 (1089)	10-1/2 (267)	3	689 (4445)	C	405 (184)

* See page 2 for check valve piping style.

Blowers listed are satisfactory for duct pressures from -0.5" w.c. to 0.2" w.c. (-1,2 mbar to 0,5 mbar).
For other conditions, see Data 140-5 for blower details and sizing.

Air Inlet Dimensions in Inches (mm)

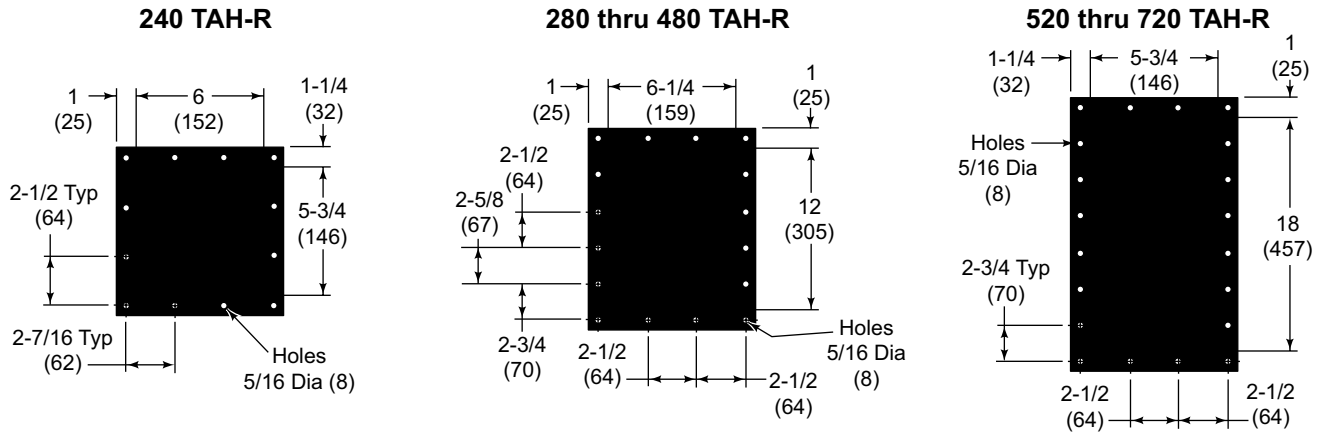

Pilot Components and Dimensions in Inches (mm)

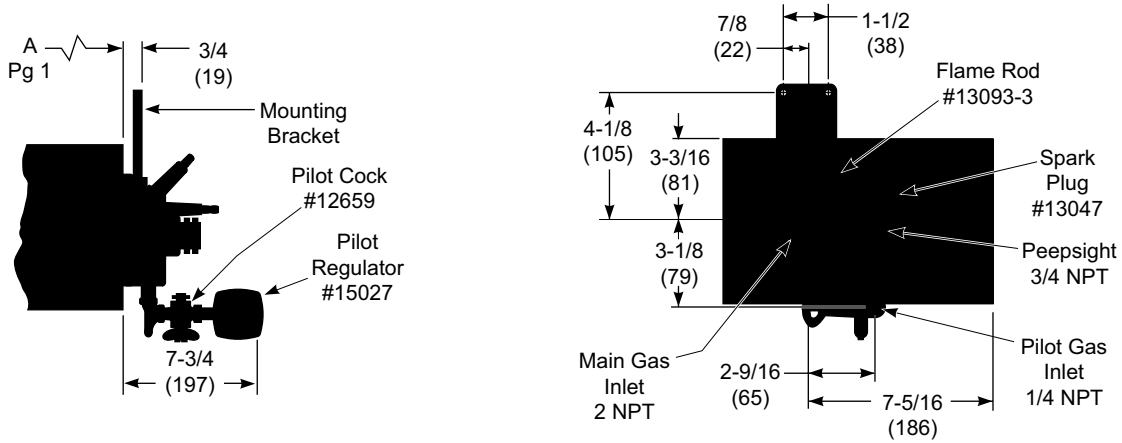

Check Valve Pipe Styles

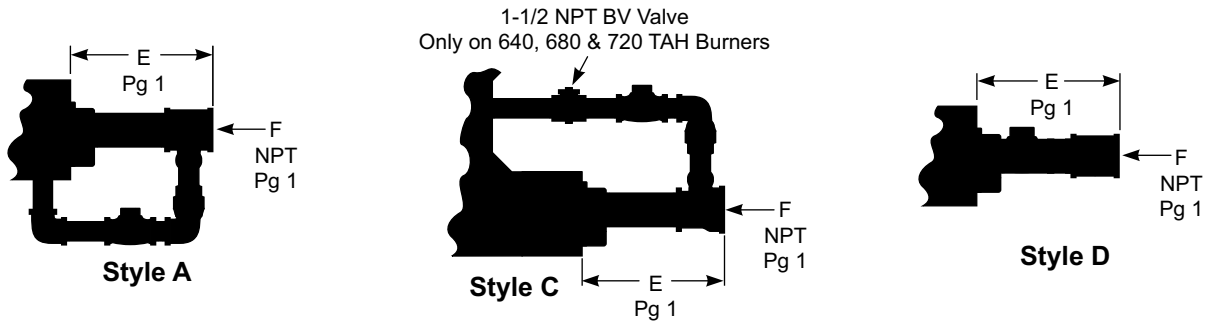

Check Valve Assembly Number

240 TAH-R	550096	1"
280 thru 400 TAH-R	550100	1-1/4"
440 thru 720 TAH-R	550104	1-1/2"



Offered By:

Power Equipment Company
2011 Williamsburg Road
Richmond, Virginia 23231
Phone (804) 236-3800
Fax (804) 236-3882

www.peconet.com